



*Experiences on implementing
CAPE-OPEN components
using the .NET framework*

Lars von Wedel
AixCAPE e.V., Aachen

Cannes, France
9 March 2005

AixCAPE: Innovation-oriented network

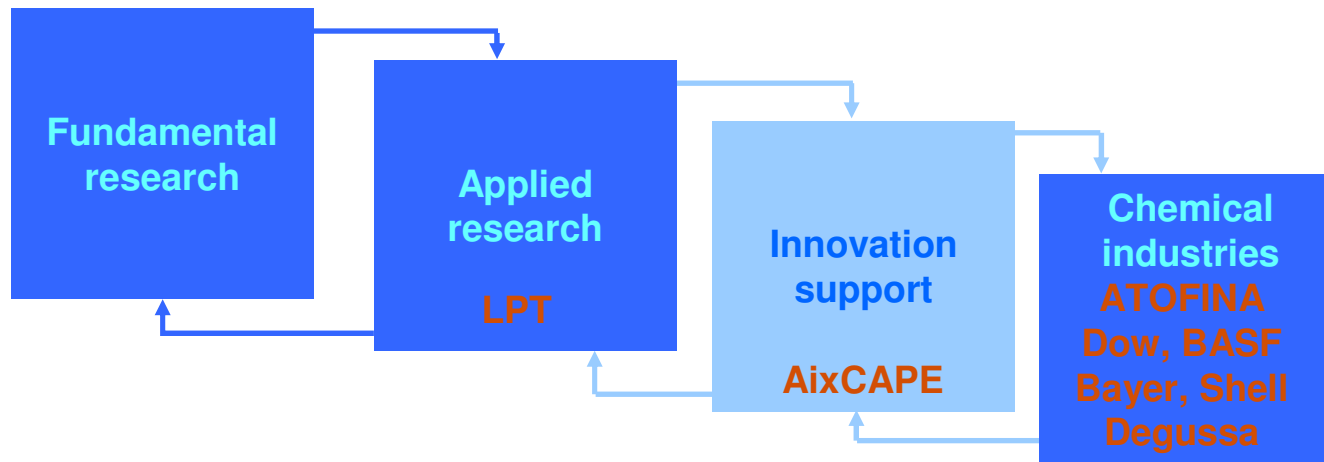

- **Use of research results**
 - Often difficult in practice
 - Not only a technical problem
 - AixCAPE supports the process of innovation
 - Screening of new methods and tools
 - Evaluation of novel developments in practical cases
 - Implement research results in pre-commercial products
 - Feedback of requirements and potential into research



Presentation outline

- The .net framework as a new programming paradigm
 - Managed execution
- Advantages
 - Interoperability, Installation, Security, Reflection
- A safe path for migration
 - Integration with „legacy“ techniques
- Nuts and bolts
 - How is .net applied for vertical issues?
 - Registration, collections, persistence, error handling
- A working example
 - Shortcut unit from LPT/RWTH Aachen as a CAPE-OPEN unit



The .NET Framework: A New Programming Paradigm

- Started in 2000 (first public presentation of visions)
 - Java oponent
 - Platform to cover mobile devices
- First release published 2002 (.net Framework 1.0)
- Current (unmanaged) process execution
 - Code is generated for a physical processor
 - Code directly accesses CPU and other computer ressources

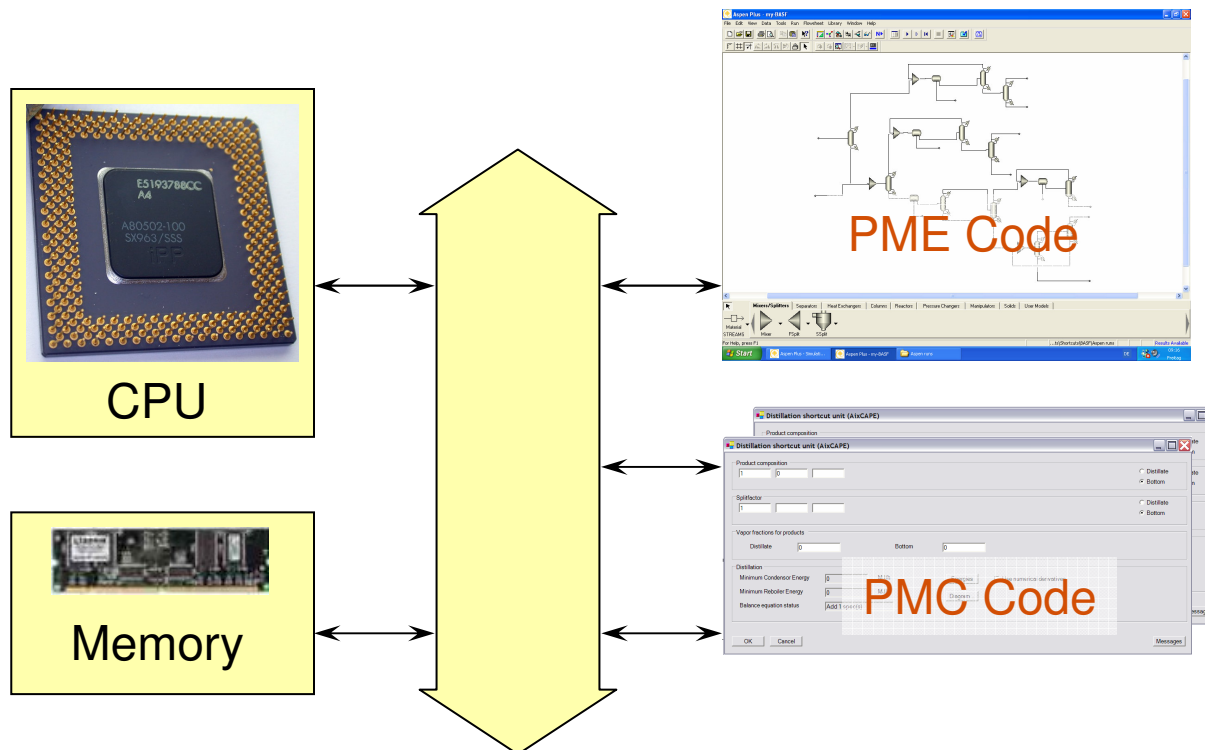

AIXCAPE



Managed Execution

- A *virtual machine* (Common Language Runtime, CLR)
 - hosts *managed code* which is
 - written in an *intermediate language* (IL)
- Only the CLR accesses physical resources
- IL code is compiled just-in-time (JIT)
 - Speed penalty negligible (5%)

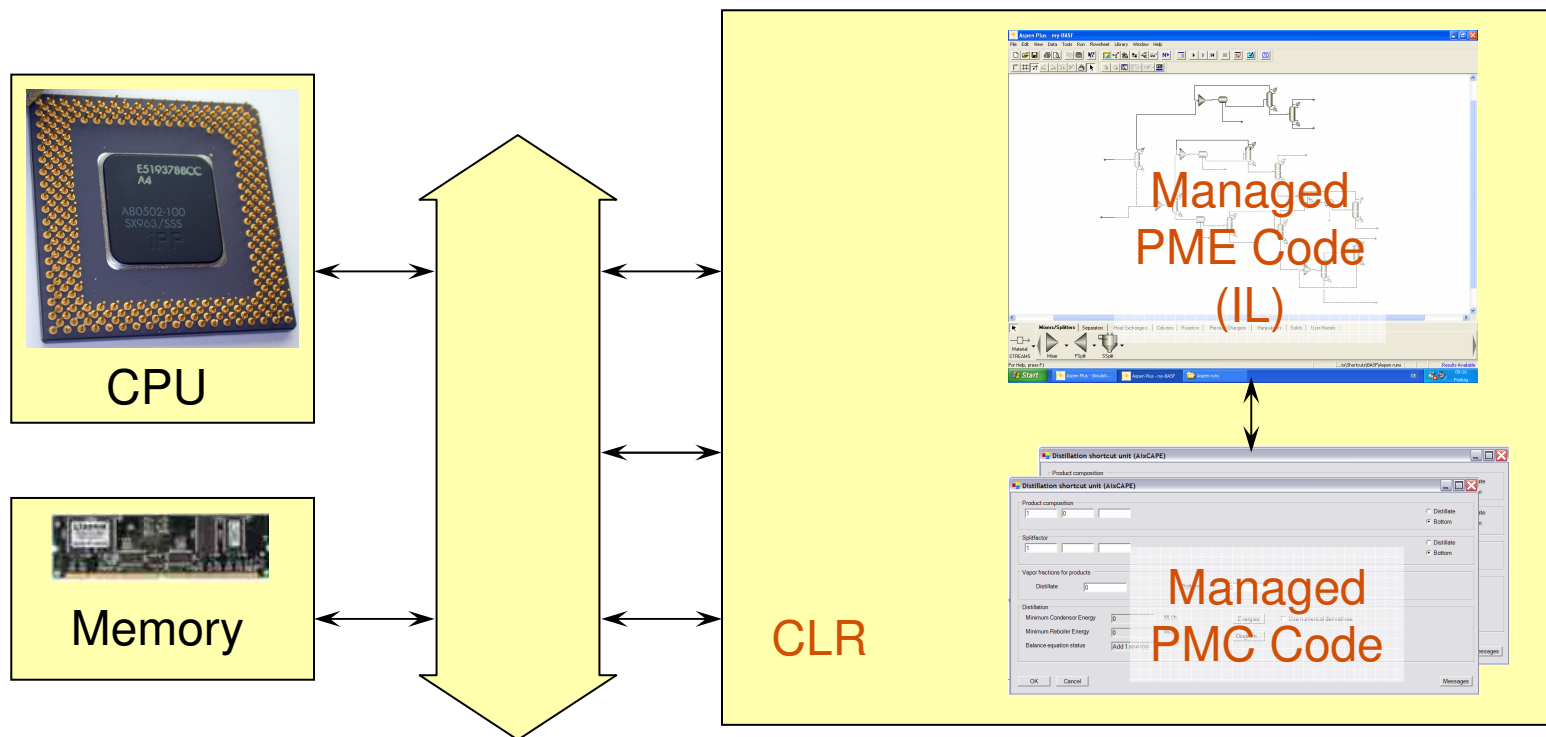

About Assemblies

- An Assembly is a unit of code
- Assemblies incorporate meta data
 - Version (e.g. 1.0.4366)
 - Language
 - Strong name / Signature
 - Type information
 - ...

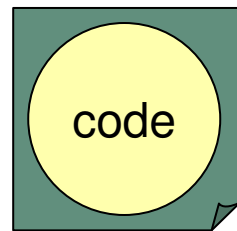

unit.dll

Unmanaged
Code

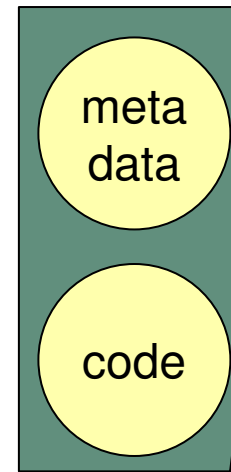

unit.dll

Managed
Code



Advantages of Managed Execution

- Interoperability
 - Mix and match of languages feasible
- Versioning
- Deployment
 - Registration no more needed
- Security guards
 - CLR can be instructed to restrict access
- Localization
 - CLR can be „switched“ to french, german, english, ...
- Remoting
 - Can be realized by the CLR instead of the application
- Changes of the underlying hardware
 - New CPU generations, SMP, ...
 - Mobile devices
 - CLR for the target hardware is sufficient
- ...



Path to Incorporate .NET Components

- COM-based PME's with „managed PMC's“
 - Component callable wrappers (CCW)
- „managed PME“'s with COM-based PMCs
 - Runtime callable wrappers (RCW)
- Use Fortran, C, C++
 - Platform Invoke services
 - Short: P/Invoke

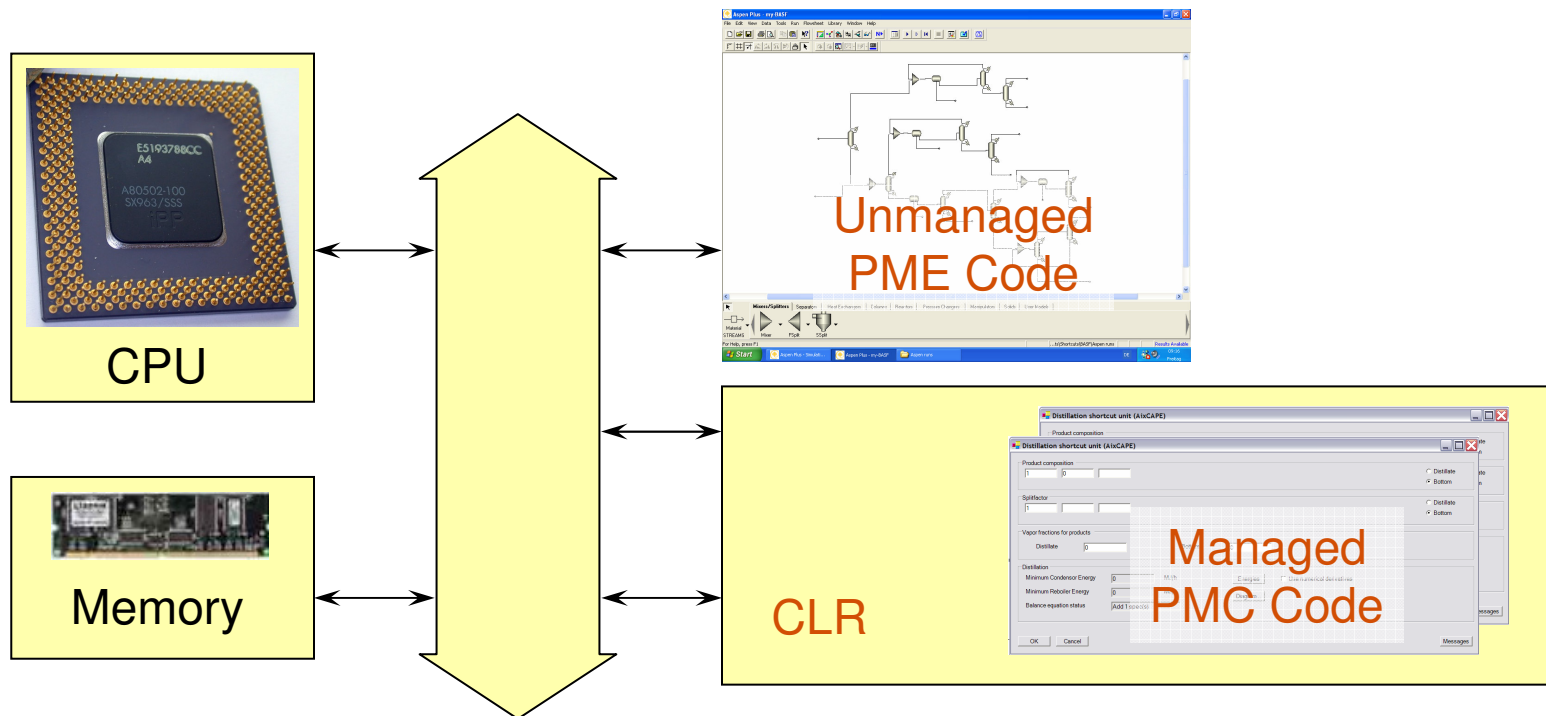

COM-based PMCs in a managed PME

- Example
 - AspenPlus mixer/splitter in .net simulator
- Wrapper needed to bridge differences
 - Runtime Callable Wrapper (RCW)
 - Generated automatically by CLR from TLB!
 - Improvements can be implemented manually

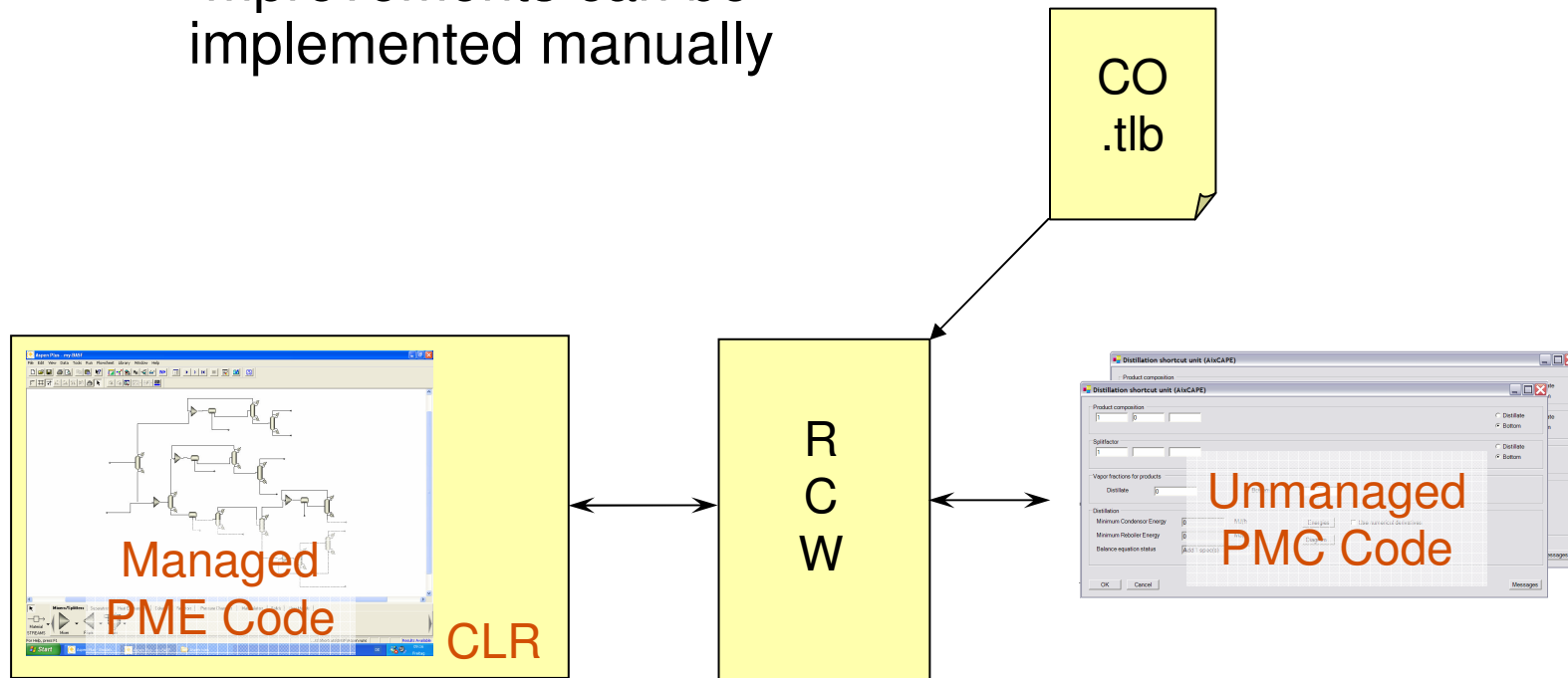

Managed PMC in a COM-based PME

- Probably more interesting example
 - Large PMEs based on COM exist
 - Rewriting them in managed code is unlikely
- Wrapper needed to bridge differences
 - Component Callable Wrapper (CCW)
 - Generated automatically from CAPE-OPEN type library

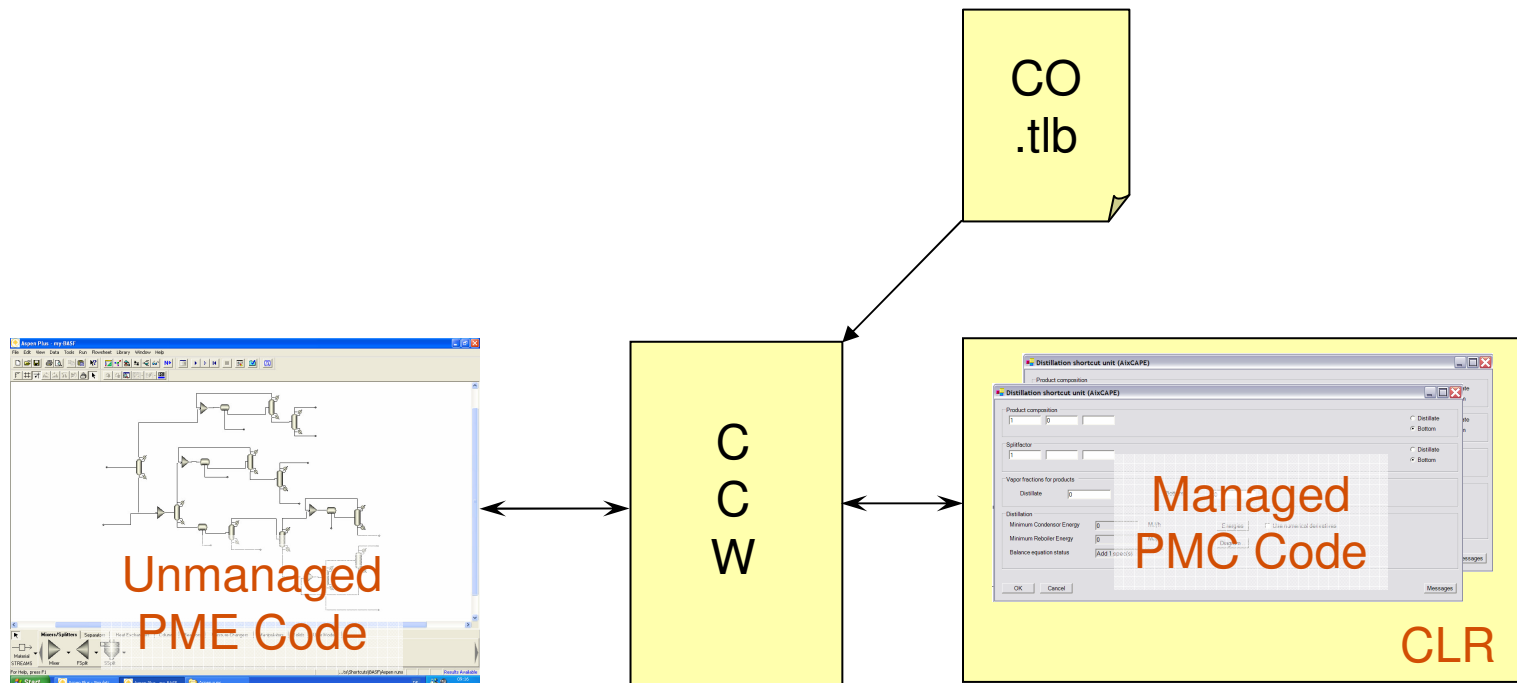

Interop Assemblies

- Wrappers „live“ in a special assembly
 - Interop assembly
 - Generated from COM type libraries
 - tlbimp.exe comes with the free .NET SDK
- Primary interop assembly
 - Signed by „vendor“
 - can be shared by different applications
 - Should be supplied by COLaN

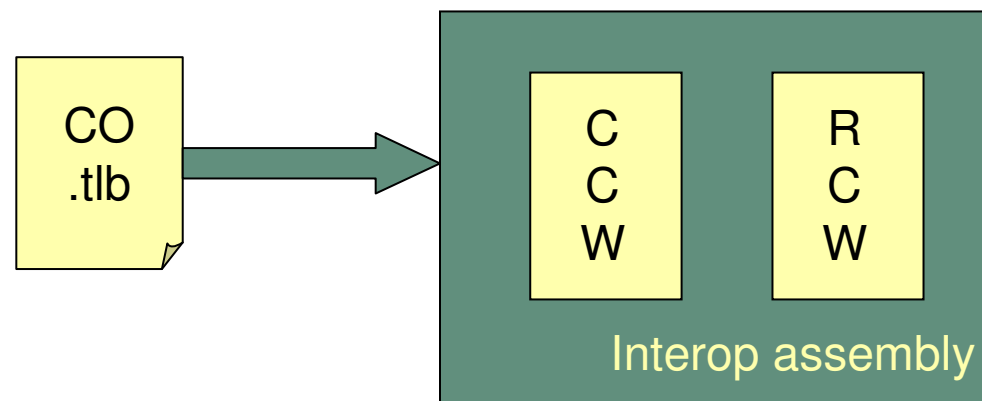

- Mechanism to deal with existing DLLs
- Use existing code in .NET written in
 - C, C++
 - Fortran
 - ...



Nuts and Bolts for CAPE-OPEN development

Some vertical mechanisms need a little investigation

- Registration
- Collections
- Persistence
- Error Handling
- ...

Look at the blog on the AixCAPE website

- <http://www.aixcape.org/Members/lvw/implementing-cape-open-with.net>
- Material to be contributed to SIG on M&T



Example: Shortcut Models in a Flowsheet

Shortcut model for distillation (LPT, RWTH Aachen)

- Calculate minimum energy
- Determine feasibility

Integration RBM / Simulator

- Shortcut as a block
- Stream connections to other blocks
 - Further columns
 - Reactor models
- Treatment of recycles
- Integration of thermodynamic models and properties data

Application procedure

- User specifies flowsheet
- Direct specification of products
 - Simple – like splitter
- Analysis by simulation
 - Shortcut Block: minimum energy
 - Advantage computation time, robustness

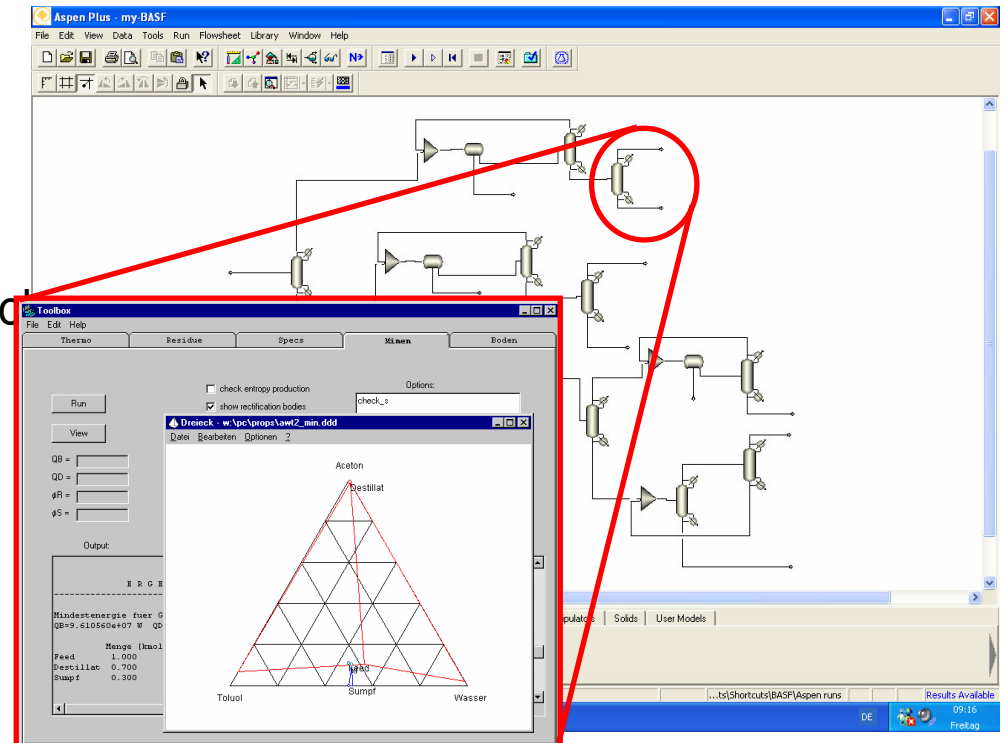

Technical realization with CAPE-OPEN

Analysis of existing Architectures

- CAPE-OPEN
- Shortcut Toolbox
 - Uses results vector (double[]) to communicate stream data
 - Uses abstract interface for property calculations already
 - IK-CAPE, PLIB, ...
 - User interface needed for specification of separation
 - Bridge needed to make material object available as a property provider

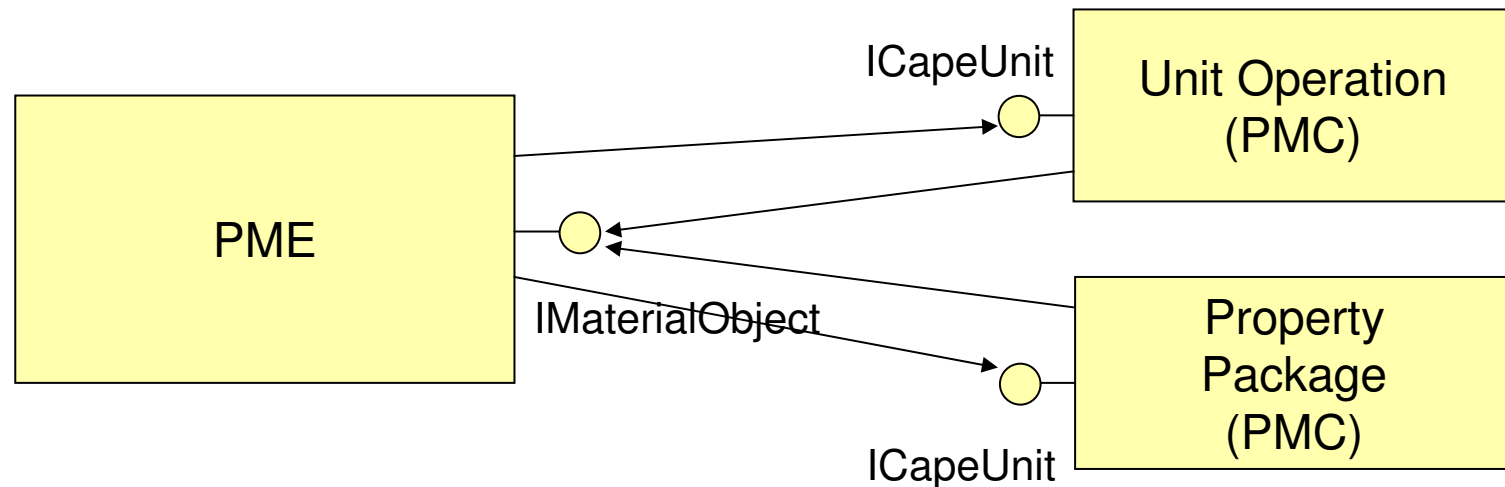

AixCAPE



Process Modeling Environment

Process Modeling Components

Implementation of Shortcut Unit

Shortcut Unit

- Dynamic library toolbox.dll
 - Realized in C at LPT
 - Thermodynamics, azeotrope search, rectification body method
- Shortcut Unit (AixCAPE)
 - Developed using Microsoft .net / C#
 - GUI (Parameterization)
 - Stream connections (ports)
- Material Object Adapter (AixCAPE)
 - Written in C++
 - Adapt material object interface

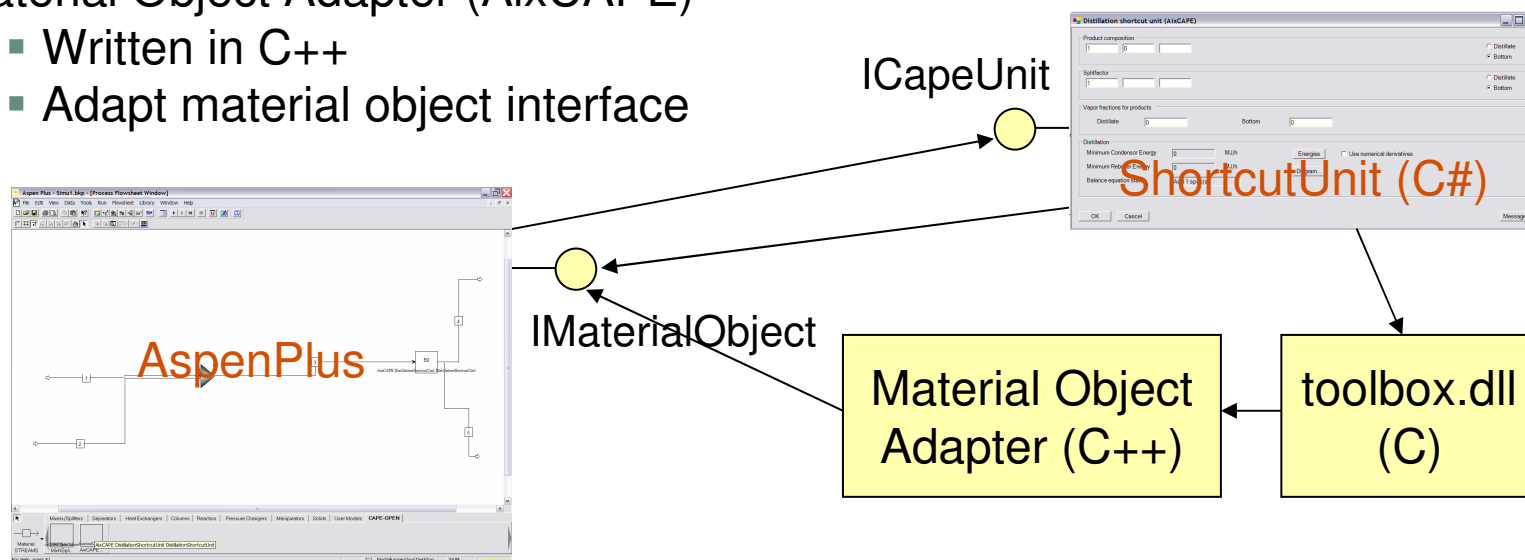

Process Modeling Environment

Process Modeling Component

AixCAPE





- .NET is an interesting, new approach for software development
 - Several features easier than in COM
- Integration with existing COM code successful
 - A smooth migration path into the future
- AixCAPE participates in new M&T SIG
 - Contribute experiences from shortcut unit coding
- CAPE-OPEN/.NET consulting also possible
- Acknowledgements